

DO NOT SCALE DRAWING
THIRD ANGLE PROJECTION

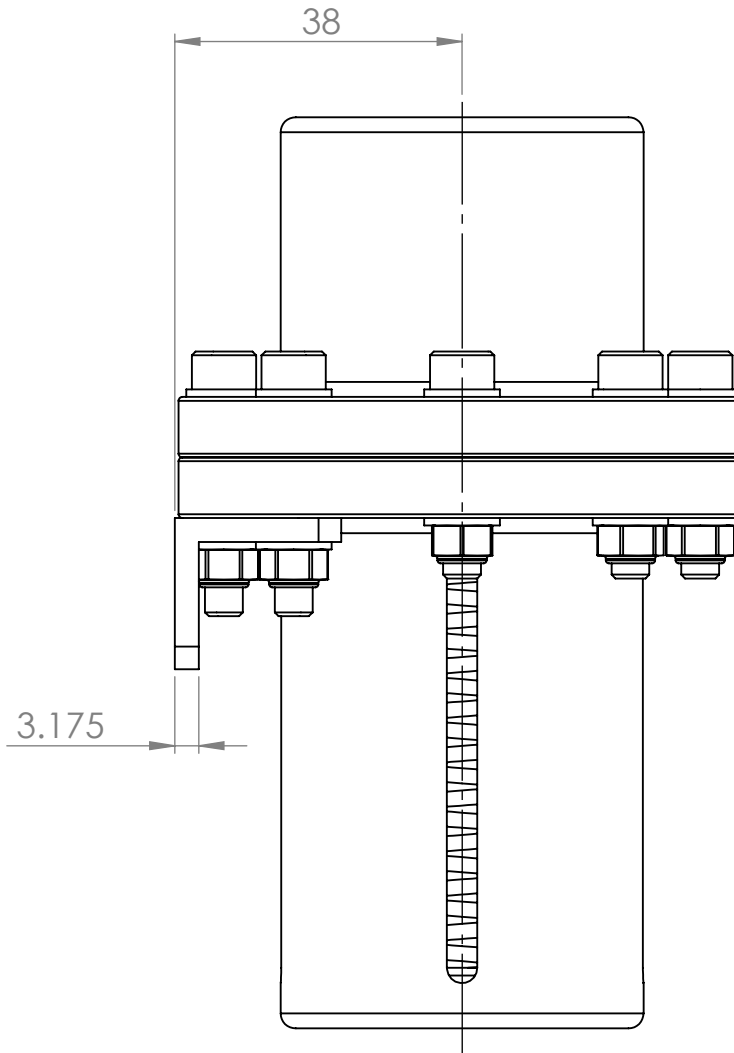
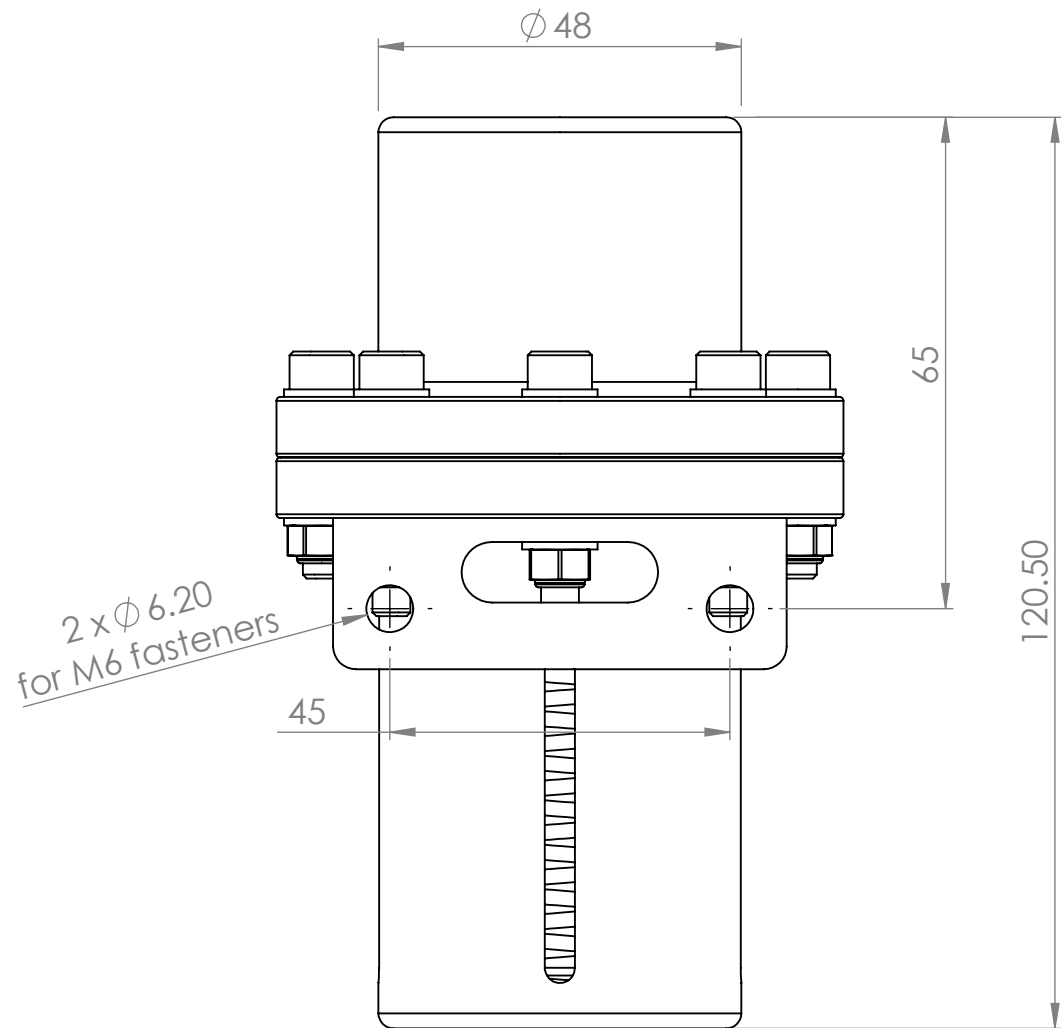
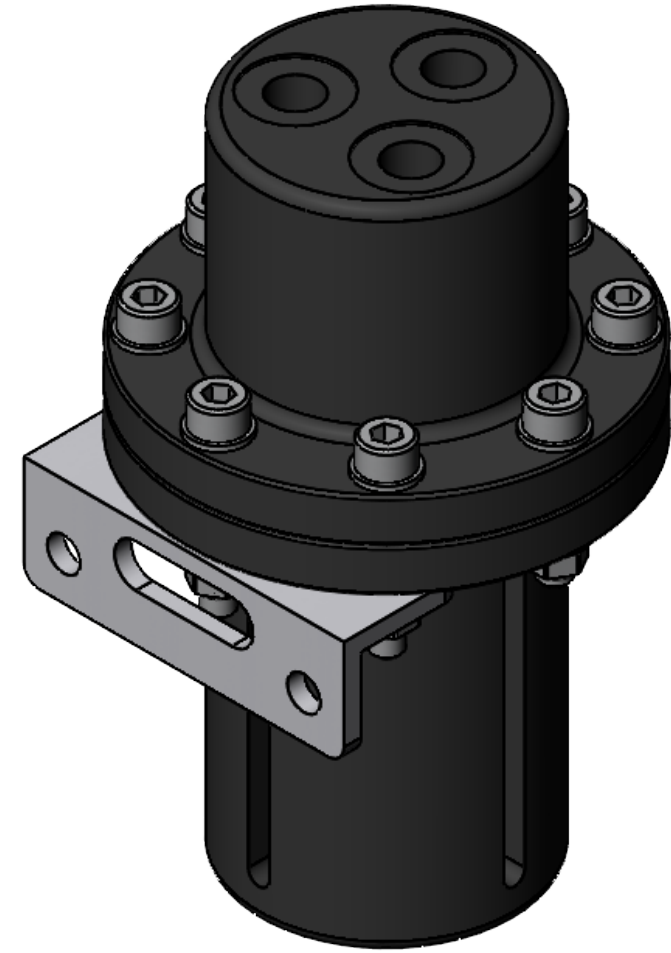
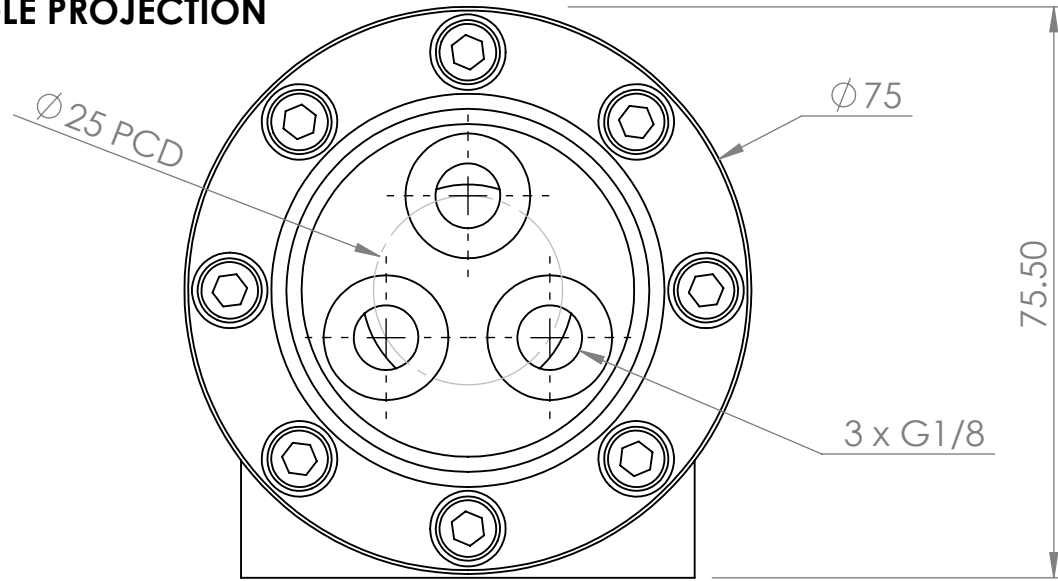

NOTES

1. Compensator capacity: 74cc
2. Max working pressure: 1.1bar

REV	DRAWN	APPV'D	DATE	DESCRIPTION
1	DGM		18/07/24	ISSUED FOR INFORMATION

RECORD OF REVISIONS

Macduff Robotics Ltd
Aberdeen, Scotland.
www.macduff-robotics.com
enquiries@macduff-robotics.com

MATERIAL:
-
FINISH:
-
TOLERANCE:
+/- 0.1mm
WEIGHT:

TITLE:
74cc Compensator Assembly
3 x 1/8bspp ports
SHEET 1 OF 1
DWG NO. GA0009
SCALE:1:1
REVISION 1
A3

DIMENSIONS ARE IN MILLIMETERS, UNLESS OTHERWISE SPECIFIED